



Whole Home Central Air Cleaning System

MODEL 600 Hepa Shield

In 1985, the manufacturer was the first company to introduce a Whole-House TRUE HEPA filtration system. Today the 600HS Hepa Shield is the standard by which all other filtration systems are measured. By utilizing the efficiency of the HEPA filter, the 600HS has adopted the same filtration effectiveness as required in hospital surgery rooms, clean rooms and other applications where the removal of harmful respirable particles (**less than 1 micron in size**) are necessary.

Hepa Shield PLUS

The manufacturer is the first company to utilize the new GE ECM Variable Speed, low energy use motors for its Hepa Shield line. The 600HS now comes in our PLUS version that offers TRUE 21st Century digital motor control technology that is unavailable in any other whole-house filtration system. Two PLUS versions. HVAC and DCU/VS.

**The *FIRST* Whole-House HEPA Filtration System...
And The *LAST* System You'll Ever Need.**



STANDARD 600HS

**REMOVES PARTICLES
0.3 MICRONS IN SIZE
AND SMALLER**

**ATTACHES TO ALL FORCED
AIR SYSTEMS. CAN ALSO
BE USED STAND-ALONE**

**POWERFUL 1/3 HP
BLOWER/MOTOR ASSEMBLY
STANDARD OR ECM MOTOR
600 CFM AIR FLOW**

THREE-STAGE FILTRATION



600HS PLUS HVAC

THE 600 HEPA Shield - A Unique Design Setting The Standards For Air Filtration Systems

HOW IT WORKS

Rated as the best whole-house filtration system, the 600 HEPA Shield unit utilizes the patented by-pass design to attach to any forced air ducted heating/cooling system up to 5 tons. The 600HS unit is attached to the return-air side of the heating cooling system in a by-pass configuration. The powerful 1/3 HP blower pulls over 600 CFM of air through the prefilter, carbon and True HEPA filter and handles the pressure resistance across these three filters so the heating/cooling system fan sees no additional resistance. The by-pass configuration will handle 40% to 60% or more of the air through the heating/cooling system at any time, so the 600HS will see all the air coming through your heating/cooling system after the second pass. This allows for up to 48 air changes per 24 hours for most homes. And...even in the by-pass configuration, the 600HS unit has proven to be more efficient in removing respirable size particles than any in-line filter currently on the market. We always recommend that you keep your standard air filter in place in your heating/cooling system when using the 600HS unit.

UNIQUE SPLIT HOUSING DESIGN CONFORMS TO ANY FORCED AIR DUCTED SYSTEM

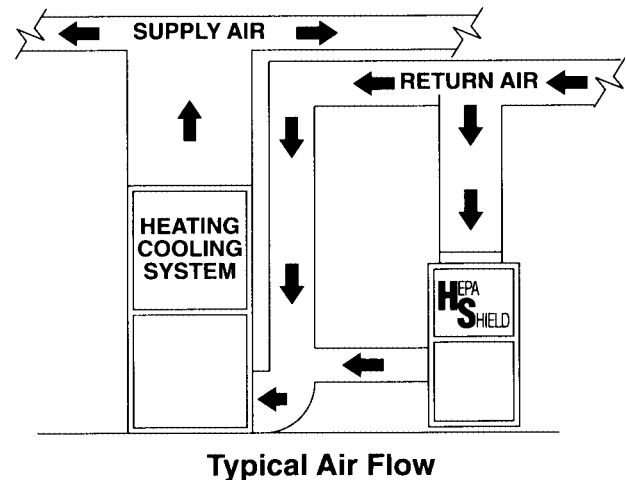
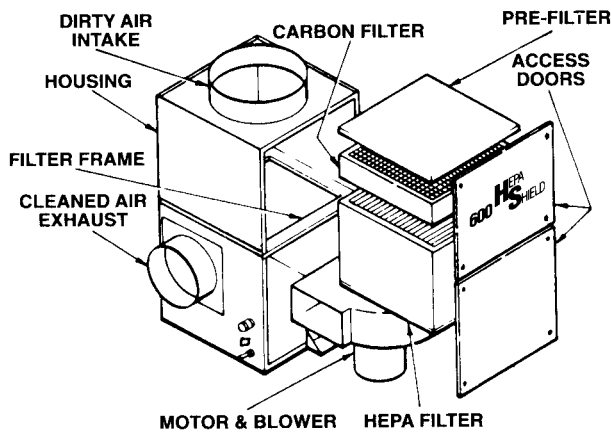

LISTED
Air Filtering Appliance c
1N18

DESIGN SPECIFICATIONS

Dimensions:	16 1/4 x 16 1/4 x 34
Weight:	97 lbs
CFM Rating:	600 CFM (Delivered)
Electrical Req:	110 volt, 15 Amp Circuit
Connections:	12" Inlet - 10" Discharge

MULTI-PURPOSE APPLICATIONS

The 600HS can be attached to any heating/cooling system up to 5 tons. It can be used with up-flow, down-flow, attic or crawl space system and...even in a stand-alone configuration. Can be mounted horizontally or vertically.

U.S. Patent # 4,717,402

600HS PLUS HVAC SYSTEM

BENEFITS & FEATURES OF PLUS HVAC & VS SYSTEMS

Specially programmed GE ECM motors allow the 600HS Plus to run in-sync with any variable speed drive HVAC unit. This means the 600HS Plus will run at high speed during either Heating or Cooling mode and then ramp down to one of four pre-programmed speeds during fan-only or off-demand mode. ECM motors are more efficient and can use up to **40% less electricity** than standard motors. This means quiet running, 24/7 operation for continuous filtration at exceptionally low operating costs. Capacity up to 600 CFM.

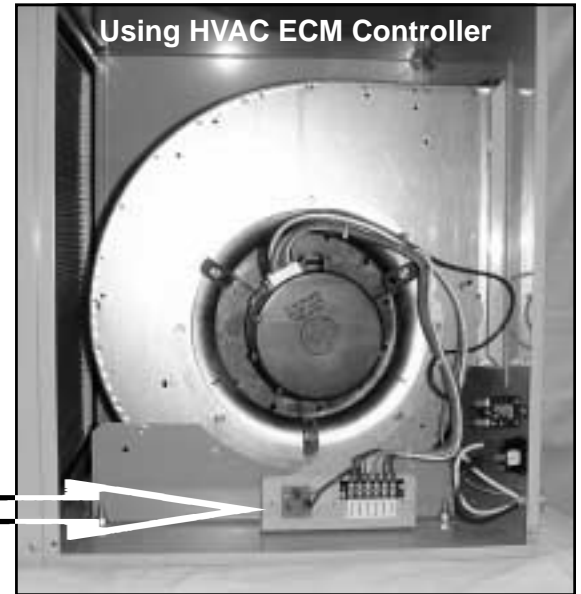

Using HVAC ECM Controller

The 600HS Plus uses a 1/3 HP GE ECM Motor. 120/240 volt, 1 ph, 60 Hz, 1050 RPM for HVAC Mode. EVO/ECM Controller with Tap Selector Board and Thermostat Connecting Block. Can be used with any type of heating/cooling system. Works off the thermostat.

600HS PLUS VS SYSTEM

The 600HS Plus can also be supplied with an EVO/DCU Controller that will allow finite variable speed control from 1% of volume to 100% of rated volume of the 600HS Plus. This feature will allow the use of the 600HS Plus for any stand-alone application where variable speed adjustment is necessary. This is a real benefit in applications where different air volumes are necessary. From 60 cfm to 600 cfm.

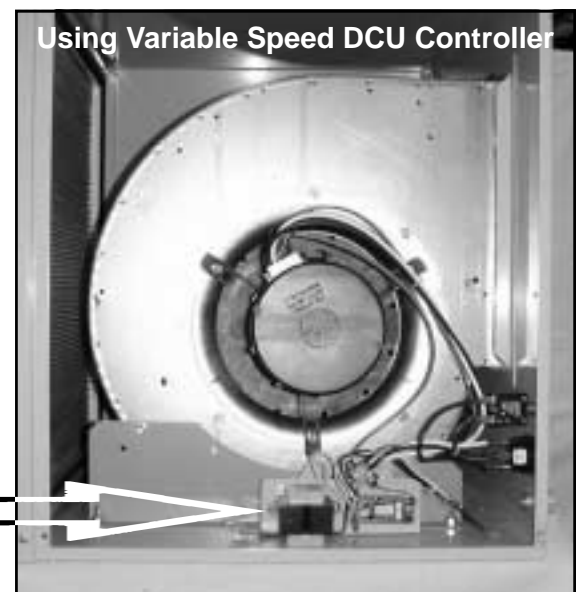
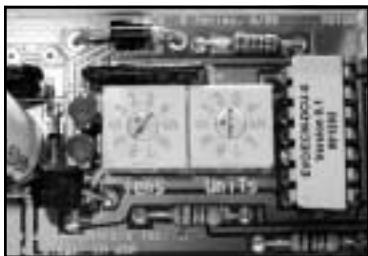

Using Variable Speed DCU Controller

The 600HS Plus VS utilizes a DCU two-set dial controller for finite control of air flow. This controller pack has its own 24 VAC transformer.

BENEFITS - FEATURES - ADVANTAGES OF THE 600 Hepa Shield

- 1.) **PATENTED BY-PASS APPROACH:** allows for installation on any heating/cooling system.
- 2.) **COMPACT DESIGN:** can easily be installed in most homes.
- 3.) **INCLUDES 3-MATCHED DESIGNED FILTERS:** prefilter, carbon filter and HEPA filter.
- 4.) **SELF-BALANCING AIR FLOW DESIGN - ADDS NO RESISTANCE.**
- 5.) **ENVIRONMENTALLY & CHEMICALLY SAFE MATERIALS OF CONSTRUCTION.**
- 6.) **EASY TO MAINTAIN:** all 3 filters easily accessible through top access door.
- 7.) **FULL THREE (3) YEAR WARRANTY:** on all blower, motor and electrical components.
- 8.) **TAKE IT WITH YOU WHEN YOU MOVE:** easily removed for installation in another home.
- 9.) **INTRODUCE FRESH, FILTERED AIR THROUGH THE 600HS.** add outside air through the unit.
- 10.) **FILTER REPLACEMENT FOLLOW-UP PROGRAM:** computerized customer reminder system.
- 11.) **AMERICAN MADE - U.L. LISTED.** each 600HS is constructed of all American made products.
- 12.) **MOST RECOMMENDED:** the 600HS is recommended by more Allergists, Medical Professionals, Architects, and Environmental Organizations than any other system on the market.

Introduce Fresh, Filtered Air

The 600 Hepa Shield system can be used to introduce fresh, filtered air from the outside...or it can be used in conjunction with Heat Recovery Ventilation Systems.

Carbon Adsorption

The five pound carbon filter will reduce many household odors and gases such as pet odors, chemicals, mildew, ammonia, formaldehyde & ozone.

REMOTE OPERATION FOR THE 600HS PLUS STAND-ALONE DCU/VS VERSION

The 600HS PLUS VS version can be used in any application where you do not have a forced air ducted system or where independent filtration is required. NEW Infrared remote and wired remote operations are now available for this unit.

ATTACH THE 600HS PLUS HVAC VERSION TO ANY HEATING/COOLING SYSTEM

The 600HS PLUS HVAC version can be attached to any type of heating/cooling system. While it is designed to operate in concert with the newer variable speed drive HVAC systems, by simply using the thermostat as a control signal, it can be installed with any single, two or three speed heating/cooling systems.

For Ordering Contact:

Natural Solutions Environmental, Inc.

Voice: 1-847-577-7000

Fax: 1-847-577-7045

<http://www.naturalsolutions1.com>